

Single Line Parallel Lubrication System



Multiple Point Lubrication Using Oil or Grease

LubriSystem

Automated Centralized Lubrication System that can be used in virtually any application where centralized operation is desired.

- Dependable
- Economical
- Versatile
- Adjustable injector outputs
- Up to 100 or more lube points
- Use with oil or grease
- Wide range of options
- Modular design
- Option of aluminum or stainless steel injectors and manifolds

INTRODUCTION

LubriSystem™ utilized one of three (3) types of pumps: a single-stroke air-operated pump; a multiple-stroke hand-operated pump; or a continuous flow, electric motor pump. Fed from a lubricant reservoir mounted above, the pump output is delivered to oil or grease metering valves (called meters or injectors) which distribute lubricant to bearing points. Oil or grease (NLGI #1 or lighter) may be used with the hand-operated and air-operated pump. Oil or NLGI #00 or lighter grease may be used with the electric motor pump. Air-operated pumps require a solenoid-operated air valve and controller to activate the pump. Electric motor pumps use an electric motor (115 VAC is standard) and a solid-state timer device to activate the pump. The injectors are mounted in manifolds supplied by Graco. The bearing point injectors mount at the bearing point and require no manifold. Various accessories are available to simplify installation. An optional pressure switch or gauge may be added at the pump outlet port if required.

LubriSystem is referred to as a single-line, parallel system. This means that when the solid-state timer, controller or operator activates the pump, lubricant is forced down a single main line to manifolds, and from there through parallel lines from individual injectors to the lube points. If bearing point injectors are used, no manifolds are required. Instead, the single main line branches into parallel lines feeding the bearing point injectors. In both cases the injectors inject lubricant to a bearing shown in Figure 1. Once lubricant is dispensed at the lube points, system pressure is vented by the pump. This allows the injectors to prime themselves in preparation for the next lubrication cycle.

SYSTEM COMPONENTS

Pumps

Positive displacement, air-operated pumps are available in two (2) pressure ratios. A manually-operated pump and an electric motor pump are also offered. Several different types and sizes

of reservoirs allow a system to be designed precisely for your application. Reservoirs include a fill stud for reservoir refilling.

Timer

Solid-state timer can be set to control the solenoid or motor to initiate lube cycle at intervals of 1/2 minute to 32 hours.

Manifolds and Injectors

One manifold can distribute lubricant to as many as eight (8) injectors. Injectors come in six (6) sizes to meet a range of lube requirements. Bearing point injectors are fed directly from the pump through parallel branch lines and require no manifold.

Tubing, Hardware, Fittings and Accessories

LubriSystem utilizes tough 3/16 in and 5/16 in heavywall nylon tubing and brass fittings for lube points. Mounting hardware and accessories such as reservoir low-level switches and injector indicator assemblies are available.

FEATURES AND BENEFITS

A more efficient method of applying lubricant, resulting in less machine downtime, increased productivity, and a safer work environment. In addition to these benefits, LubriSystem also provides:

- Stainless steel injectors and manifolds available for corrosive environments
- Easy system design and modification
- Inexpensive components and installation
- Fast payback! In terms of savings in lube maintenance man-hours alone, LubriSystem usually pays for itself within the first year
- Easy adjustability to meet a wide range of operating conditions
- Quick-connect fill stud on pump permits complete refill in minutes
- High-pressure pump can serve more points with longer tubing runs
- Pump construction internally relieves system pressure, requiring no extra cost in external valving
- Several reservoir sizes available to fit a variety of applications
- Visual indicator pin available for system diagnostics

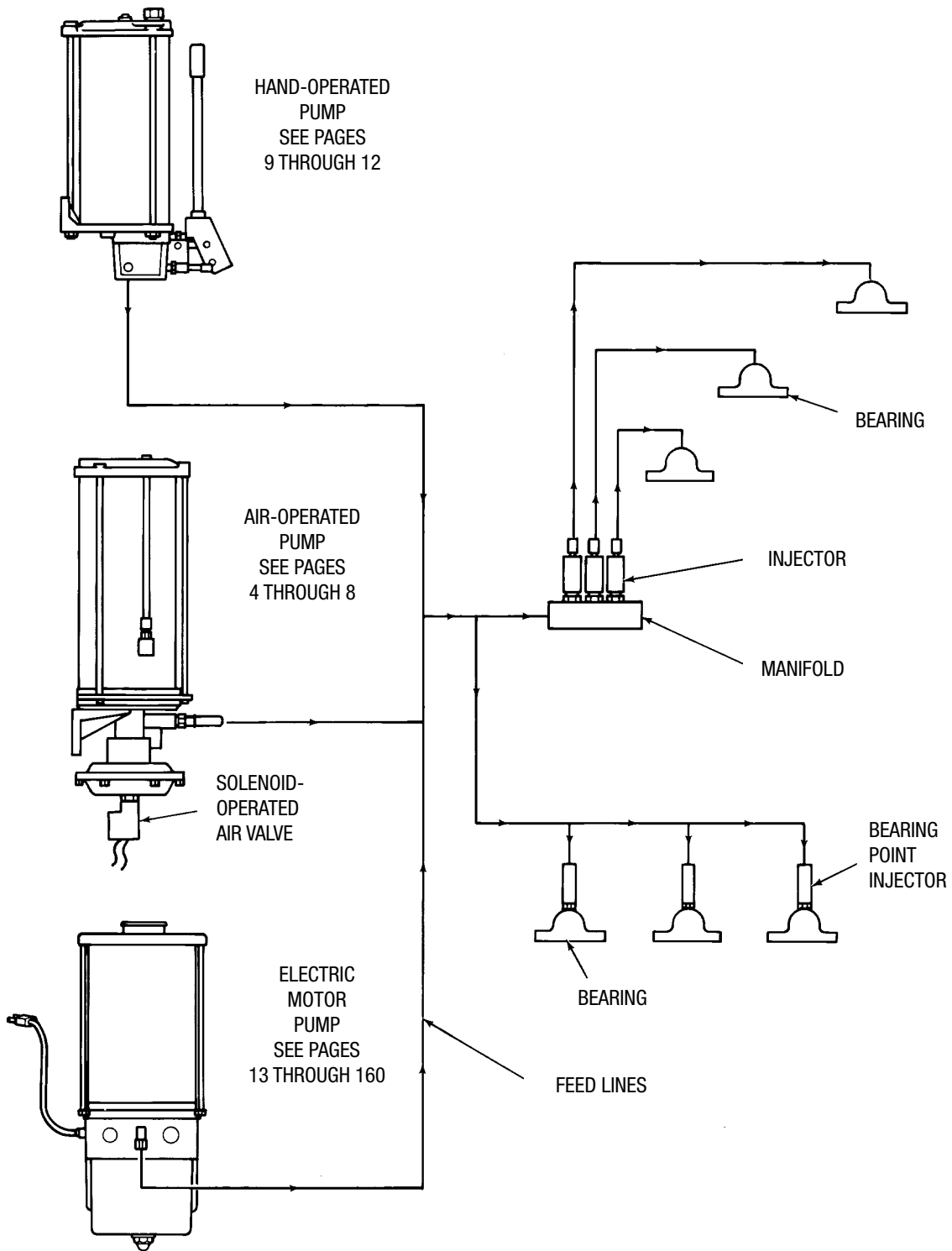

Figure 1. LubriSystem Diagram

SYSTEM OPERATION

As shown in Figure 1, when the electric motor or solenoid-operated air valve receives a signal from the timer, or when the operator actuates the handle, the pump is activated. The pump dispenses lubricant either into the mainline tubing which distributes the lubricant to the manifolds, feeding each injector, or to lines supplying bearing point injectors. Each of the injectors is sized to measure and dispense the proper amount of lubricant based on the size of the bearing. Details of the operation of each component are included in this brochure.

INTERCHANGEABILITY

LubriSystem components are functionally interchangeable with other commonly used single-line, parallel injector systems. Air inlet and lube outlet ports are 1/4-8 NPT, typical of most other pumps in the field. Injectors have a 3/16 in tube connection as standard. An accessory indicator/adaptor allows 1/8 in tubing to be connected to the outlet. Mounting dimensions of LubriSystem components are very close to those of other systems. And, if some components, there is a direct interchangeability in form and fit as well as function.

APPLICATIONS

Typical applications of LubriSystem include the following:

- **Mobile Equipment**
 - Front End Loaders
 - Haul Trucks
 - Blast Hole Drill Rigs
 - Paving Equipment
- **Plastic/Rubber Industrial Equipments**
 - Tire Presses
 - Injection Molders
- **Food Processing Equipment**
 - Peelers
 - Washers
 - Mixers
 - Ovens
 - Conveyors
 - Can-making Machines
- **Packaging Equipment**
 - Palletizers
 - Stackers
 - Wrappers
- **Lumber Equipment**
 - Debarkers
 - Edgers
 - Slasher Decks
 - Planers
 - Stoker Grates
 - Saw Guides
 - Winders
 - Presses

AIR-OPERATED PUMPS

DESCRIPTION

LubriSystem air-operated pumps (Figure 2) are available in two lube-to-air power ratios to meet your system requirements. The standard pump has a 9:1 ratio while the high-pressure pump provides a 24:1 ratio. Output per stroke is 1.5 cubic inches (24.59 cm³) for standard pumps and 1.4 cubic inches (22.95 cm³) for high-pressure pumps. Both pump bodies are made from strong, lightweight aluminum and are furnished with a corrosion-resistant coating. This coating provides a tough, durable, impact-resistant finish which is exceptionally resistant to corrosion; excellent for salt spray or humid environments. Pump piston and cylinder bore are precision machined and finished to minimize wear and discourage corrosion.

Reservoirs in several different sizes are available in transparent plastic. All reservoirs mount directly to the pump and are easily interchangeable. The level of lubricant in the reservoir is easily checked due to the transparent plastic.



Figure 2. Air-Operated Pump

SYSTEM SIZING AND CALCULATIONS

* To check that a system is not oversized for a pump, the following calculations need to be performed:

1. Sum the output volume of all injectors used in the system.
2. Add the number of injectors used in the system and multiply by .004 cu. in. This is total volume required to re-prime the injector.
3. Total system requirement is the sum of 1 and 2, and should be less than 50% of the total output per cycle for the pump selected. (The 50% is a rule of thumb to allow for line expansion and fluid compressibility.)

If totals are more than 50% of pump output, the following steps can be taken:

1. Select smaller injectors and increase system cycle frequency.
2. Split the system up and use 2 or possibly more pumps.

All reservoirs used with grease are equipped with a spring-loaded follower which provides a positive, air-free supply of grease to the pump. Pumps are equipped with a fill stud and strainer to allow easy filling of the reservoir from a supply source. Oil reservoirs are also equipped with a fill cup and strainer, allowing easy refilling from an oil can. Optional low-level switches, timers and solenoid-operated air valves are available to custom design your application.

The solenoid-operated air valve, designed for use with air-operated pumps, is controlled by a solid-state timer or other electronic controller. The solenoid is a 115 VAC, three-way, normally-closed valve with a manual override. The manual override simplifies system testing, line filling, and line bleeding by allowing the operator to control when the pump dispenses lubricant. When the solenoid receives a 115 VAC signal from its controller, it actuates the valve to allow air flow to the pump. While the solenoid is energized, the pump strokes forward sending lubricant through the system. When the solenoid is de-energized, the pump piston returns. An FR unit (FRL with high pressure pumps) must be used upstream of the air valve to remove harmful dirt and water from the air supply. Air pressure should be a maximum of 100 psi (7 bar) for the high-pressure pump or 150 psi (10 bar) for standard pumps.

MOUNTING

Sturdy bracket, with four mounting holes, holds pump with solenoid and reservoir. Assembly should be mounted in a protected, centralized, and readily accessible location. Pump must be mounted in a vertical position only, with reservoir up. Use four 5/16 inch or M8 machine screws at the mounting holes to ensure secure placement.

FEATURES / BENEFITS

Proven dependable performance. Many pumps now in use have logged over 5 years of trouble-free operation. Pump features include:

- Simple design—few moving parts results in less wear and downtime.
- Compact modular construction allows you to customize the pump/reservoir design to fit your application.
- Lube supply status at a glance.
- Rugged aluminum construction to provide lightweight features with heavy-duty capabilities.

OPERATION

Figure 3 portrays the air-operated pumps in the “at-rest” position. The figure represents both standard and high-pressure pumps. The description of operation applies to both. At this point, air is not present and spring (8) pressure has moved piston (7) to the down position. When the piston is down, flapper valve (1) opens and lubricant from reservoir fills lube chamber (9) above the piston. Spring pressure on check valve (4) prevents lubricant from flowing through the outlet port. This condition also allows residual pressure in the lube lines to raise ball (3), pass through screen (2) and return to the reservoir. This venting of the output lines allows injectors to prime themselves.

When air at 40 to 100 psi (3 to 7 bar) is applied to air inlet port (6), pressurized air fills air chamber cavity (12), forcing piston (7) upward, pressurizing lubricant in lube chamber (9). The pressurized lubricant closes flapper valve (1) (preventing the discharge lubricant from being fed back to the reservoir) and forces check valve (4) open, allowing lubricant to flow through lube outlet port (5) to the injectors. When air pressure is removed, spring (8) returns piston (7) to the down position to repeat the cycle. On the standard pump a diaphragm (10) is used to seal the air chamber cavity (12), on the high-pressure pump, this is accomplished by a lip seal (11).

OPTIONS

Low-Level Switches

Several assemblies are available to provide a signal when the lubricant level is low. Low-level switch assemblies used on oil reservoirs depend on floats that fall with the depletion of lubricant and actuate contacts on the switch. Switch assemblies used on grease reservoirs are actuated when a cable attached to the grease follower is pulled away from the switch as the follower reaches the low position. Limit switch assemblies used on grease reservoirs are rated at 15 amps. Oil reservoirs use 10-watt reed-type switches.

The low-level assemblies with a 15 amp rating are often used to activate a warning device such as light or alarm. The 10-watt assemblies are used to provide input to controllers which may be programmed to use the input signal as desired.

Solid-State Timer

This solid-state timer can be used to initiate pump cycles on a time basis at intervals from 1/2 minute to 32 hours. A built-in memory retains the cycle time for 1-1/2 hours during power failure or machine shutdown to resume from the point where it was suspended. For details, see Literature No. 14521. Sophisticated multi-function controllers are also available for use in systems using pressure switches. Refer to literature No. 14540 (LC-1000) and 14750 (WMP III).

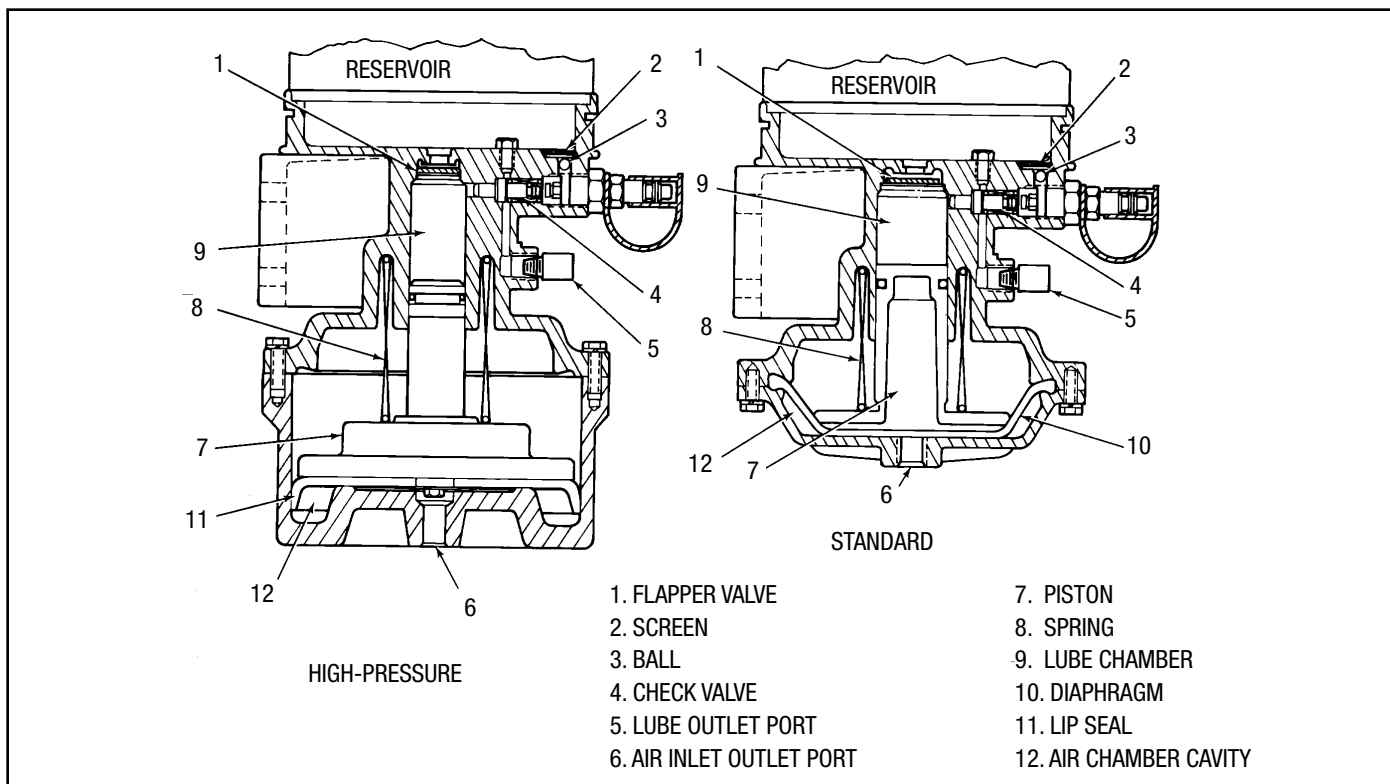

Figure 3. Air-Operated Pump Operation

SPECIFICATION	
Pumps:	
Air Inlet Pressure	
Standard	40 to 150 psi (3 to 10 bar)
High-Pressure	40 to 100 psi (3 to 7 bar)
Lube Outlet Pressure	
Standard (9:1)	360 to 1350 psi (25 to 93 bar)
High-Pressure (24:1)	960 to 2400 psi (66 to 165 bar)
Pump Output per Stroke	
Standard	1.5 cu.in. (24.59 cm ³)
High-Pressure	1.4 cu.in. (22.95 cm ³)
Air Inlet Port	1/4-18 NPSF
Lube Outlet Port	1-4/18 NPSF
Operating Temperatures (w/NLGI #1)	40°F to 135°F (4°C to 50°C)
Lubricant	Oil or Grease (NLGI #1 or lighter)
Type	Air-actuated positive displacement
Low-Level Switches:	
Grease or Oil Reservoir 15 amp Switch	
115 VAC	15 amp

125 VDC	0.5 amp
250 VDC	0.25 amp
Type	Single-pole, double-throw
Oid Reservoir Only - 10 Watt	
115 VAC	10 Watt
Type	Single-pole, single-throw reed type switch, normally-open or normally closed
Solid-State Timer:	
Electrical	115 VAC, 50/60 Hz, 3 amp (max)
Temperature range - Operating	0°F to 131°F (-18°C to 55°C)
Storage	-67°F to 185°F (-55°C to 85°C)
Enclosure	High Impact Plastic
Component Technology	Solid-State CMOS
Cycle Frequency, Adjustable	
Range 1	1/2 min to 30 mins
Range 2	1/2 hour to 32 hours
“On” Time	0.2 min to 13 mins
Standard; LED Indicator, Manual Run Button; Vibrations	5g's, 50 Hz

DIMENSIONS

Figure 4 presents layouts of the standard and high-pressure pumps along with common options.

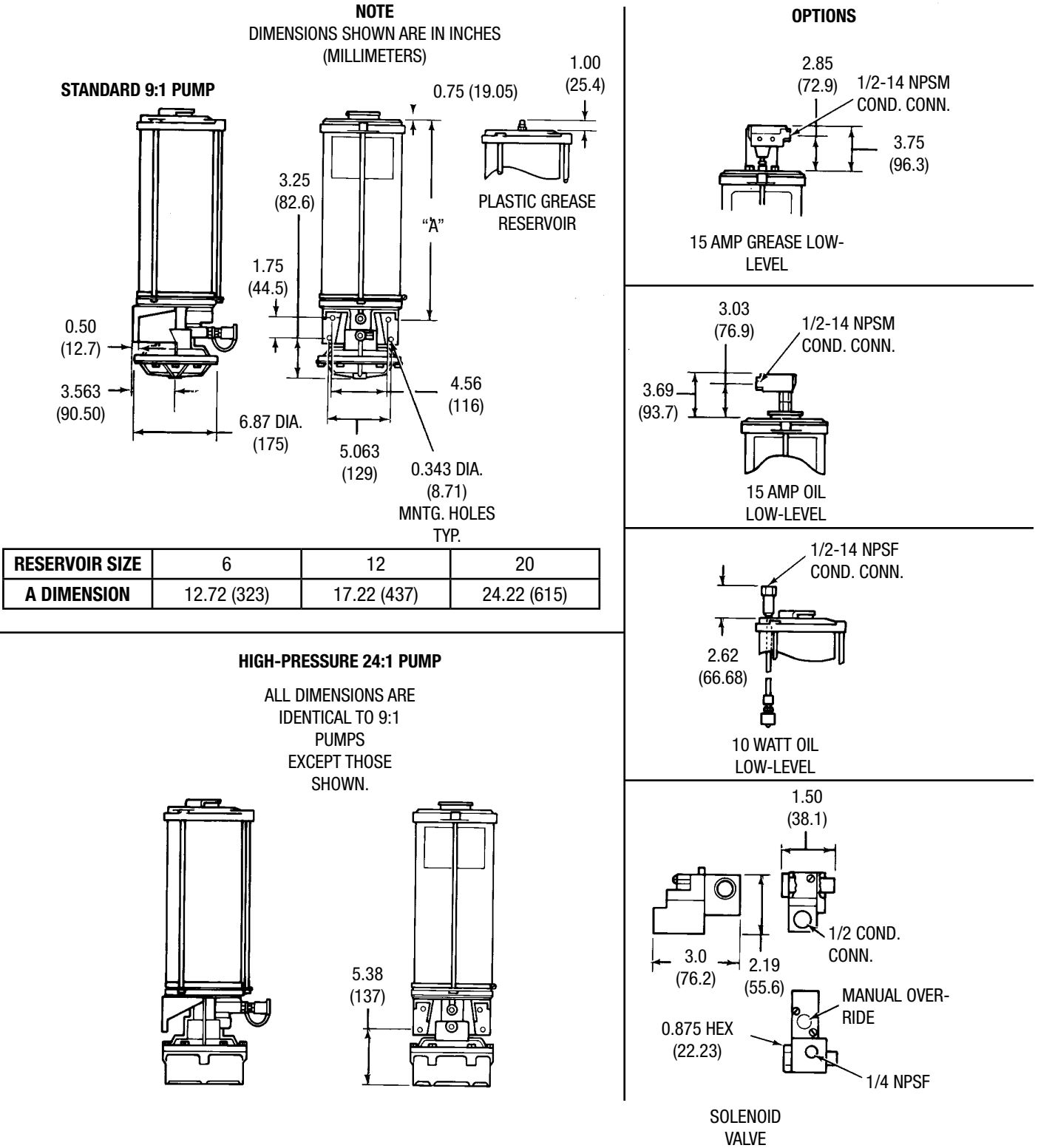

Figure 4. Air-Operated Pumps - Dimensions

SYSTEM ORDERING INFORMATION

COMPONENT ORDERING INFORMATION

LUBRISYSTEM AIR-OPERATED PUMPS		
Description	Part No.	Old Part No.
Standard - Oil		
6 pint (2.84 liter) plastic reservoir	563574	550-000-170
12 pint (5.68 liter) plastic reservoir	563575	550-000-180
20 pint (9.46 liter) plastic reservoir	563576	550-000-190
6 pint (2.84 liter) plastic reservoir w/10 watt low-level switch	563577	550-000-230
12 pint (5.68 liter) plastic reservoir w/10 watt low-level switch	563578	550-000-240
20 pint (9.46 liter) plastic reservoir w/10 watt low-level switch	–	550-000-250
Standard - Grease*		
6 lb (2.72 kg) plastic reservoir	563571	550-000-050
12 lb (5.44 kg) plastic reservoir	–	550-000-060
20 lb (9.06 kg) plastic reservoir	–	550-000-070
6 lb (2.72 kg) plastic reservoir w/ low-level switch	563572	550-000-080
12 lb (5.44 kg) plastic reservoir w/low-level switch	563573	550-000-090
20 lb (9.06 kg) plastic reservoir w/low-level switch	–	550-000-100
High-Pressure - Oil		
6 pint (2.84 liter) plastic reservoir	–	550-000-940
12 pint (5.68 liter) plastic reservoir	Dis	550-000-950
20 pint (9.46 liter) plastic reservoir	564425	550-000-960
6 pint (2.84 liter) plastic reservoir w/10 watt low-level switch	–	550-001-000
12 pint (5.68 liter) plastic reservoir w/10 watt low-level switch	–	550-001-010
20 pint (9.46 liter) plastic reservoir w/10 watt low-level switch	–	550-001-020
High-Pressure - Grease*		
6 lb (2.72 kg) plastic reservoir	563583	550-000-820
12 lb (5.44 kg) plastic reservoir	–	550-000-830
20 lb (9.06 kg) plastic reservoir	564424	550-000-840
6 lb (2.72 kg) plastic reservoir w/ low-level switch	–	550-000-850
12 lb (5.44 kg) plastic reservoir w/low-level switch	–	550-000-860
20 lb (9.06 kg) plastic reservoir w/low-level switch	–	550-000-870

LUBRISYSTEM AIR-OPERATED PUMPS COMPONENTS		
Description	Part No.	Old Part No.
Pumps		
Standard Pump (no reservoir)	563579	550-000-280
High-Pressure Pump (no reservoir)	563582	550-000-790
Plastic Reservoirs (for oil only, standard or high-pressure)		
6 pint (2.84 liter)	564265	185-100-820
12 pint (5.68 liter)	562892	185-100-380
20 pint (9.46 liter)	562893	185-100-390
Plastic Reservoir (for grease*, standard or high-pressure)		
6 lb (2.72 kg)	562907	185-100-780
12 lb (5.44 kg)	562896	185-100-540
20 lb (9.06 kg)	562897	185-100-550
10 Watt Low-Level Switch (for oil, plastic reservoir only)		
6 pint (2.84 liter) size	563014	456-010-171
12 pint (5.68 liter) size	563015	456-010-172
20 pint (9.46 liter) size	563016	456-010-173
15 Amp Low-Level Switch (for oil, plastic reservoir only)		
6 pint (2.84 liter) size	563318	521-001-050
12 pint (5.68 liter) size	563316	521-001-030
20 pint (9.46 liter) size	563317	521-001-040
15 Amp Low-Level Switch (grease applications)		
All Grease Reservoirs	563322	521-001-110
115 VAC Solenoid Valve		
	563315	521-001-020
24 VDC Solenoid Valve		
	557925	550-200-040
Solid State Timer		
	562872	163-400-000
Reservoir Mounting Hardware Kit (required for all air & electric pumps)		
	–	550-402-000
Standard Pump Repair/Rebuild Kit (includes Pump Diaphragm)		
	563762	550-400-792
High Pressure Pump Repair Kit		
	563772	550-402-500
Pressure Gauge Kit (3000 psi gauge)		
	–	550-001-780

See page 25 for Fill Studs and Couplers

* Nominal grease reservoir size is based on a direct conversion of oil reservoir capacity and does not reflect volume loss due to the follower and spring. Actual volumes contained are: 6 lb (2.6 lb), 12 lb (5.8 lb), 20 lb (11.8 lb).

HAND-OPERATED PUMPS

DESCRIPTION

The multiple stroke, positive-displacement LubriSystem Hand Pump (Figure 5) delivers 0.125 cubic inches (2.0 cm³) with each stroke of the handle. The LubriSystem Hand Pump is available with standard clear plastic reservoirs for either oil or grease. Modular pump/reservoir design plus built-in features readily tailor the LubriSystem Hand Pump to a wide range of applications.

The pump is sturdily built of aluminum and steel in a compact, space-saving package. Even with an integrally mounted 20-pint or 20-pound capacity reservoir, it stands only 25.3 inches (644 mm) high, is 7.25 inches (184 mm) wide and 11.03 inches (280 mm) deep. It requires only 24.3 inches (617 mm) clearance from the mounting surface for a full handle pull.

MOUNTING

Sturdy bracket, with two mounting holes, hold pump with reservoir. The assembly components should be mounted in a protected, centralized and readily accessible location. Pump must be mounted in a vertical position only, with reservoir up. Use two 3/8 in or M10 machine screws at the mounting holes to ensure secure placement.



Figure 5. Hand-Operated Pump

FEATURES / BENEFITS

- Interchangeable reservoirs make it easy to customize the pump package for each application.
- Simple, positive-displacement pump design keeps the number of wear parts to a minimum for extended pump life.
- Built-in bleed mechanism provides system pressure venting when the pump handle is returned to the fully upright position.
- 3000 psi pressure gauge provides a fast check on system status.

OPERATION

Figure 6 shows a cutaway view of a hand-operated pump. As the pump handle (1) is pulled down, piston (2) moves forward past the detent (3) closing the relief to tank port (4). Further forward motion of piston (2) displaces the volume of lubricant in cavity (8) through connecting port (5) and check valve (6) and to the outlet (7). The handle is then partially returned until the detent ball (3) contacts, but does not retract into, the ball indent cavity. If the handle is returned too far, the pressure built up in the lube cavity (8) will be vented, indicated by a decrease in the pressure gauge's reading. Continue to stroke the pump until the pressure gauge reads 1500 psi (103 bar) for oil or 2500 psi (173 bar) for grease). After system pressure has been attained, causing all the injectors to dispense lubricant, the pump handle is returned to the full upright position (past the detent). This allows system pressure to vent through port (4) back to reservoir, thereby allowing the injectors to reset and prime for their next delivery of lubricant.

PRESSURE GAUGES

Pressure Gauges are installed in the pump outlet to allow the operator to know when correct pressure has been attained. When correct pressure has been reached, the operator returns the handle to the full upright position, venting line pressure and allowing the injectors to reset.

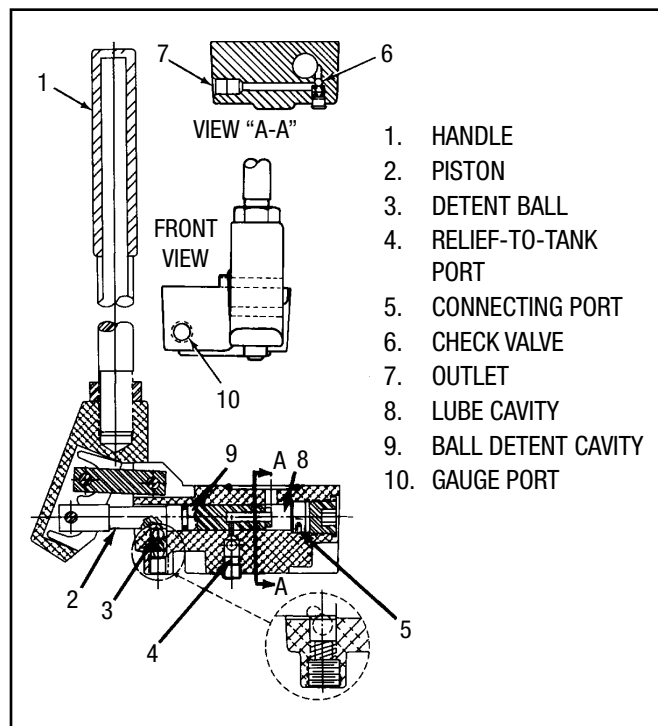

**Figure 6. Hand-Operated Pump - Operation
(Full upright position shown)**

SPECIFICATION	
Pump Body Material	Aluminum and steel
Pump Output	0.125 cu.in (2.0 cm ³) per stroke
Max Operating Pressure	3000 psi (207 bar)
Force to Operate Handle	20 lbs (9 kg) per 1000 psi (69 bar)
Lubricant	Oil or Grease (NLGI #1 or lighter)
Reservoir Capacities (for oil or grease, plastic)	6 pints (2.84 liters) or 6 lbs (2.72 kg)* 12 pints (5.68 liters) or 12 lbs (5.44 kg)* 20 pints (9.46 liters) or 20 lbs (9.06 kg)*

*Nominal grease reservoir size is based on a direct conversion of oil reservoir capacity and does not reflect volume loss due to the follower and spring. Actual volumes contained are: 6 lb (2.6 lb), 12 lb (5.8 lb), 20 lb (11.8 lb).

DIMENSIONS

Figure 7 provides dimensions for the hand-operated pump.

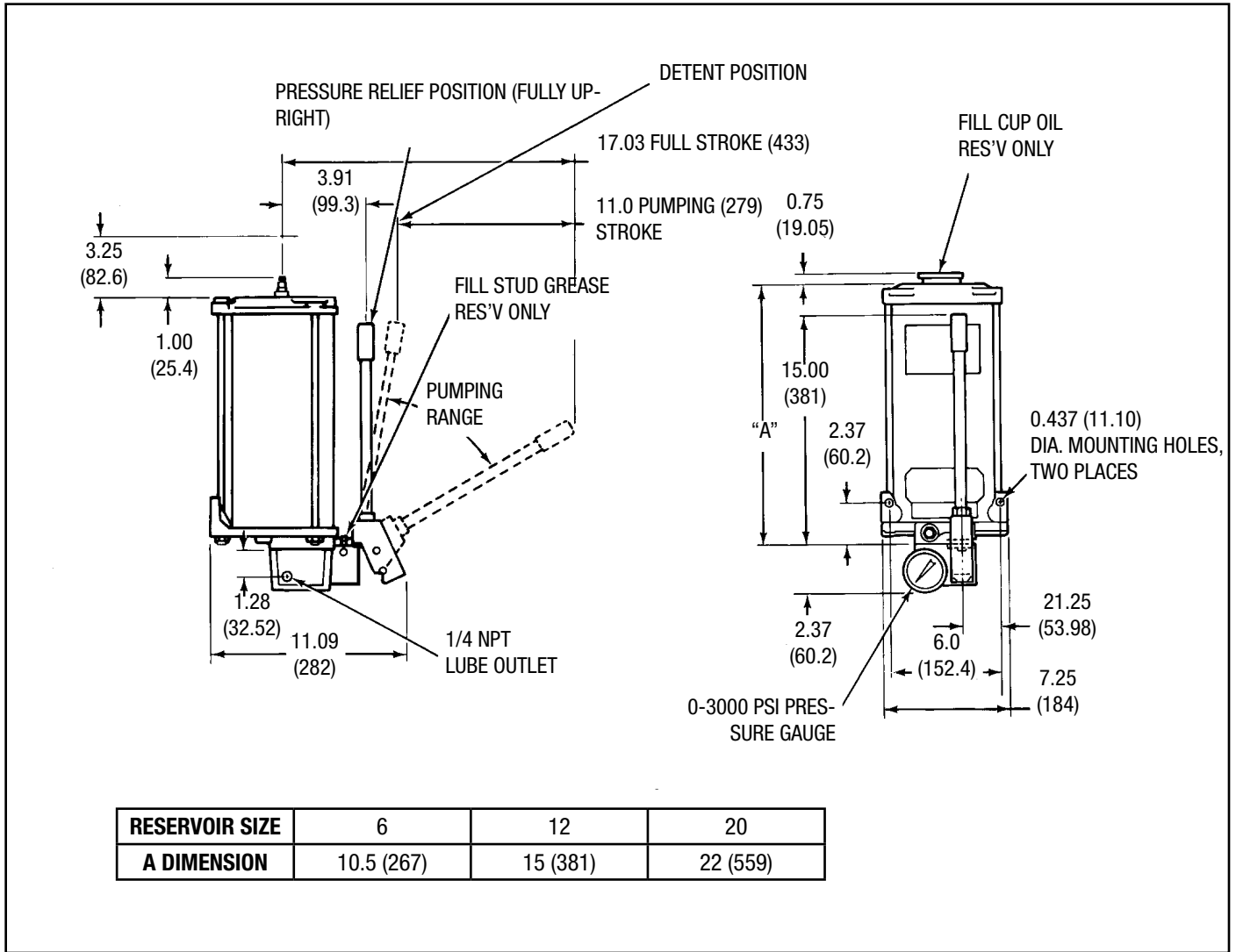

Figure 7. Hand-Operated Pump - Dimensions

SYSTEM ORDERING INFORMATION

LUBRISYSTEM HAND-OPERATED PUMPS		
Description	Part No.	Old Part No.
Hand-Operated Pump w/Plastic Reservoir for oil		
6 pint (2.84 liter) w/3000 psi gauge	–	550-000-430
12 pint (5.68 liter) w/3000 psi gauge	564419	550-000-440
20 pint (9.46 liter) w/3000 psi gauge	564420	550-000-450
Hand-Operated Pump w/Plastic Reservoir for grease*		
6 lb (2.72 kg) w/3000 psi gauge	564421	550-000-460
12 lb (5.44 kg) w/3000 psi gauge	564422	550-000-470
20 lb (9.06 kg) w/3000 psi gauge	564423	550-000-480

COMPONENT ORDERING INFORMATION

LUBRISYSTEM HAND-OPERATED PUMP COMPONENTS		
Description	Part No.	Old Part No.
Pump Assembly	563580	550-000-520
3000 psi Gauge	557864	543-362-000
Reservoirs		
<u>Plastic, used for oil:</u>		
6 pint (2.84 liter)	562904	185-100-750
12 pint (5.68 liter)	562889	185-100-060
20 pint (9.46 liter)	562890	185-100-070
<u>Plastic, used for grease:</u>		
*6 lb (2.72 kg)	562905	185-100-760
*12 lb (5.44 kg)	562884	185-100-000
*20 lb (9.06 kg)	562885	185-100-010

See page 25 for fill studs and couplers

* Nominal grease reservoir size is based on a direct conversion of oil reservoir capacity and does not reflect volume loss due to the follower and spring. Actual volumes contained are: 6 lb (2.6 lb), 12 lb (5.8 lb), 20 lb (11.8 lb).

ELECTRIC MOTOR PUMPS

DESCRIPTION

The electric motor LubriSystem pump (Figure 8) is a rugged, reliable pump for applications using oil or fluid grease as the lubricant. The motor itself is a high torque, gear-reduction motor operating at 300 rpm and 115 VAC 50/60 Hz. (Other voltages are available.) The motor drives a positive displacement, self-priming gear pump capable of pumping at a rate of 2.0 cubic inches (32.8 cm³) per minute at 1,000 psi (69 bar). All electric motor pumps are equipped with a Hirshman Connector. A 20 foot mating cable is available as an accessory (see ordering information on page 16). No motor starter or capacitor is required. Pumps may be ordered with an integral solid-state timer or control may be provided by an external system controller.

Reservoirs in several different sizes are available in transparent plastic. All reservoirs mount directly to the pump and are easily interchangeable. The level of oil in the reservoir is easily checked due to the transparent plastic. Pumps are equipped with a fill stud and filter screen to allow easy filling of the reservoir from a supply source. Optional low-level switches and timers are available to custom design your application.

MOUNTING

Sturdy bracket, with four mounting holes, holds pump with motor, timer and reservoir. The assembled components should be mounted in a protected, centralized and readily accessible location. Pump must be mounted in a vertical position only, with reservoir up. Use four 5/16 inch or M8 machine screws at the mounting holes to ensure secure placement.



Figure 8. Electric Motor LubriSystem Pump

FEATURES / BENEFITS

PUMP FEATURES INCLUDE:

- Reliable gear pump design proven in mobile equipment applications.
- Energy efficient motor uses only 25 watts.
- Allows the design of an all-electric system; no air required.

OPERATION

Figure 9 portrays the pump in the “at rest” position. When the motor (1) is energized, the gear pump (2) runs, drawing in lubricant through inlet (3). Pressure builds in passage (4) moving the poppet (5) to the right, sealing off the retainer (6) opening to the tank. As the pump continues to run, pressure exceeds the check valve (7) resistance. The check valve opens allowing lubricant to flow through internal porting to the lube outlet and injector distribution system. After 1250 psi (86 bar) is obtained, the relief valve (8) vents excess flow back to the tank maintaining constant pressure.

When the motor is de-energized, pressure relieves through the orifice (9) and the check valve closes. The accumulator effect of the system now pushes on the poppet until the force exceeds the relieving force in passage (4). At this time the poppet moves to the left, allowing lubricant pressure to vent to the tank through an opening in the retainer passage. This allows the injectors in the system to reset and prepare for the next cycle.

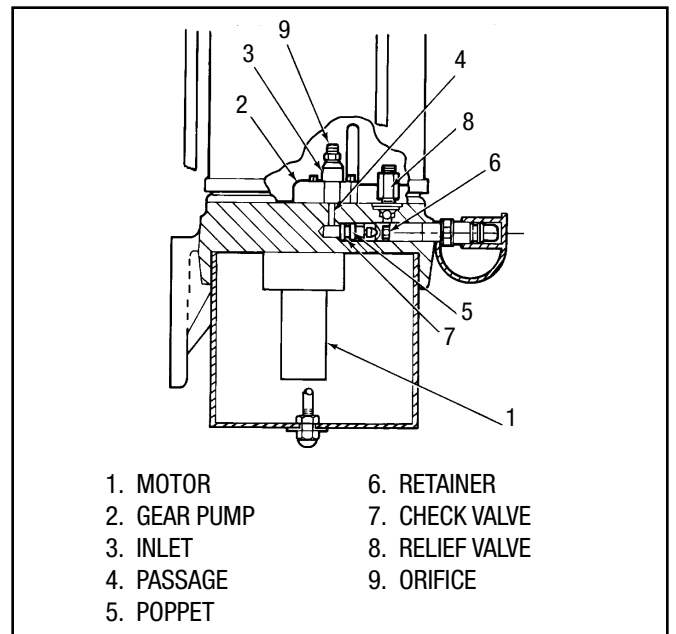

Figure 9. Electric Motor Pump Operation

OPTIONS

Solid-State Timer

If the pump is equipped with the optional solid-state timer. The “on time” and “cycle time” are controlled via screwdriver adjustable pots. A manual run button is integral with the pump to be used for system check and system filling/purging. When depressed it will activate the pump output as long as button is held in. Pressing button will not reset timer. The timer option fits neatly beneath the motor cover, adding nothing to the overall dimensions of the pump package.

Low-Level Switches

Several assemblies are available to provide a signal when the reservoir oil level is low. Low-level switch assemblies depend on floats that fall with the depletion of lubricant and actuate contacts on the switch. These switches are rated at 10 watts and are used to activate a warning device such as a light or alarm. The 10-watt assemblies are used to provide input to controllers which may be programmed to use the input signal as desired.

SPECIFICATION	
Pumps:	
Lube Outlet Pressure (max)	1000 psi (69 bar)
Pump Output	2.0 in ³ (33cm ³ per min)
Lube Output Port	1/4-18 NPSF
Lubricant	Oil (all temperatures), NLGI #00 grease for 50°F or higher, NLGI #000 grease for below 50°F
Type	Electric-motor driven, positive displacement, self-priming
Low-Level Switches:	
10 watt switch: Rating at 115 VAC	10 Watt
Type	Single-pole, single-throw reed type switch, normally-closed
Electical Specifications:	
12 VDC w/w/o timer	
Applied Voltage	12 VDC
Current Draw	5 amps
Duty Cycle	30% (run time not to exceed 2 min)
24 VDC w/w/o timer	
Applied Voltage	24 VDC
Current Draw	5 amps
Duty Cycle	30% (run time not to exceed 2 min)
115 VAC w/w/o timer	
Applied Voltage	115 ± 10% VAC, 50/60 Hz
Current Draw	0.2 amps
Duty Cycle	30% (run time not to exceed 2 min)
230 VAC w timer	
Applied Voltage	230 ± 10% VAC, 50/60 Hz
Current Draw	0.1 amps
Duty Cycle	30% (run time not to exceed 2 min)
Timer:	
On Time Range	30-90 sec
Off Time Range	10-45 min

DIMENSIONS

Figure 10 provides dimensions for the electric motor pump.

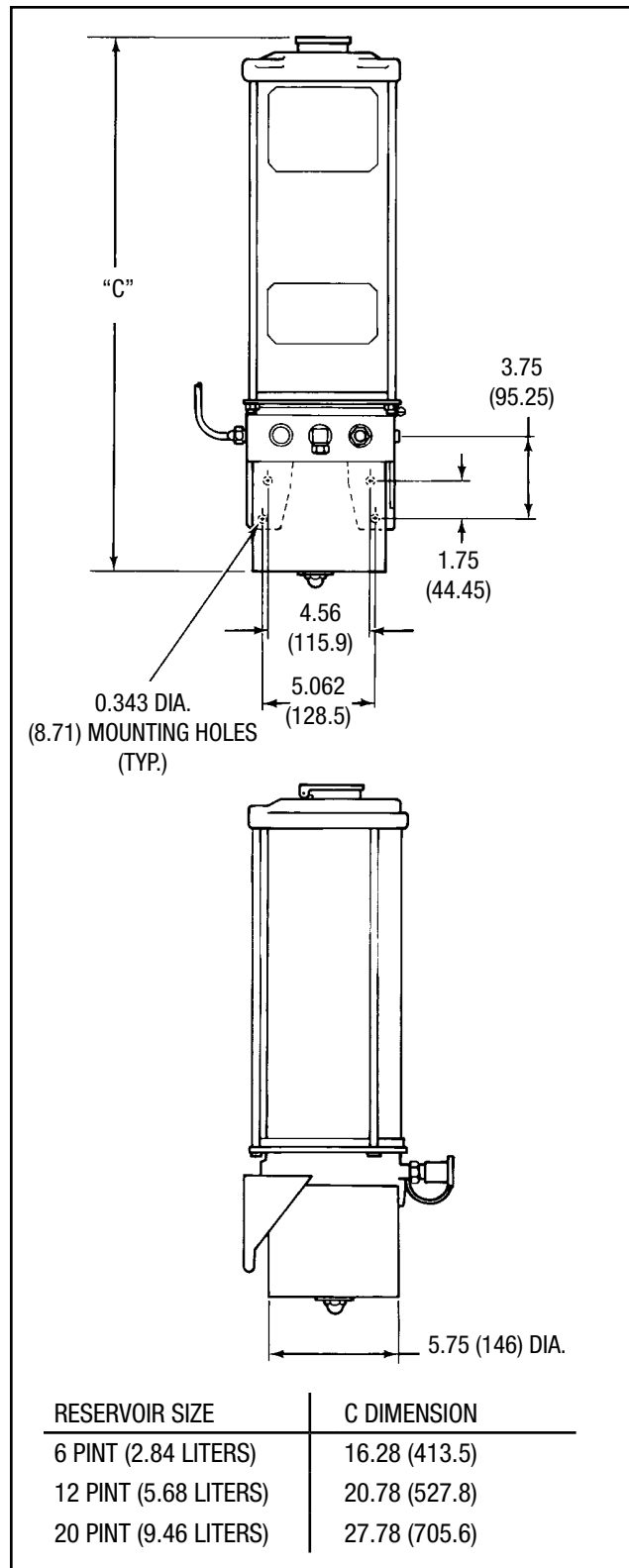
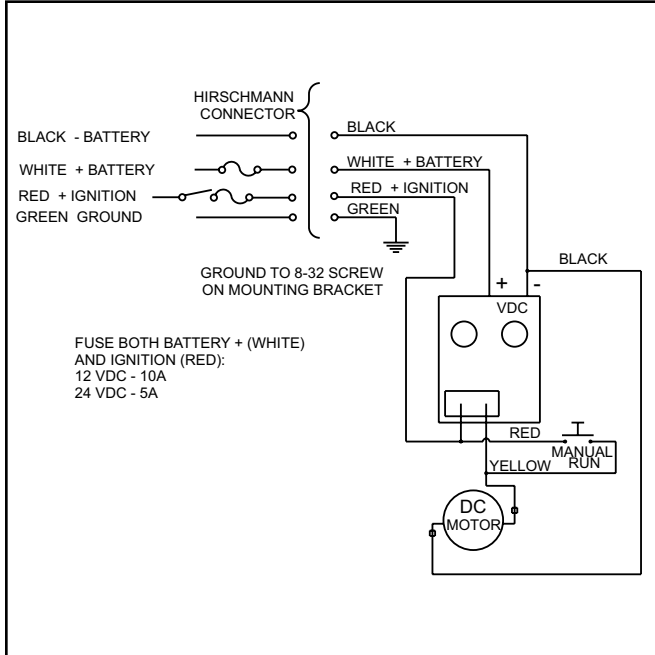
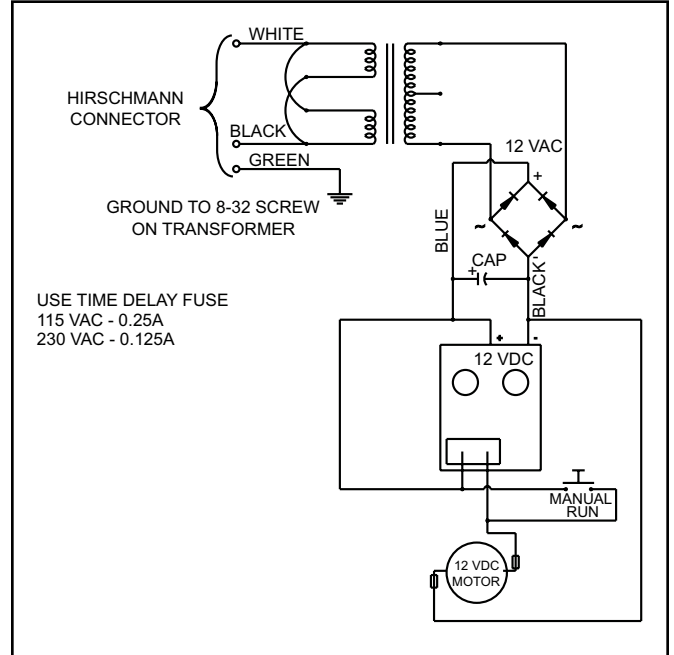

Figure 10. Electric Motor Pump - Dimensions

WIRING DIAGRAMS FOR ELECTRIC PUMPS



For 12 & 24 VDC with Timer



For 115 & 230 VAC with Timer

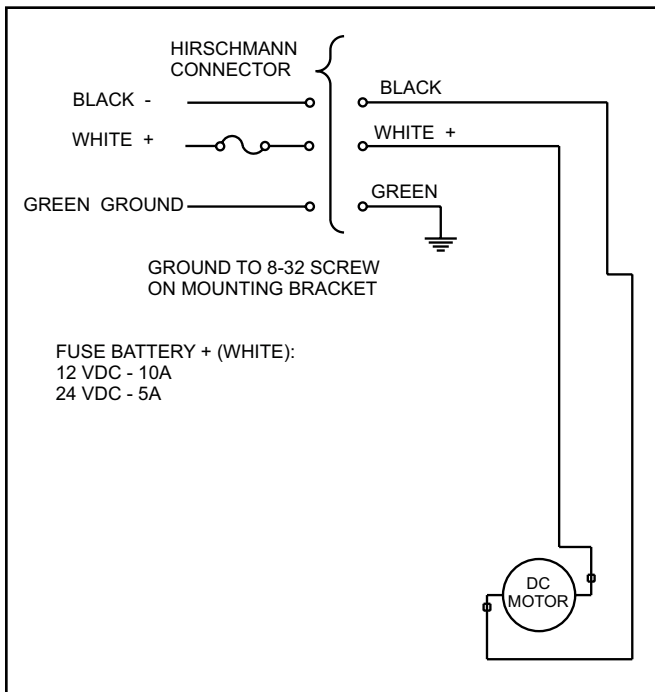

For 12 & 24 VDC without Timer

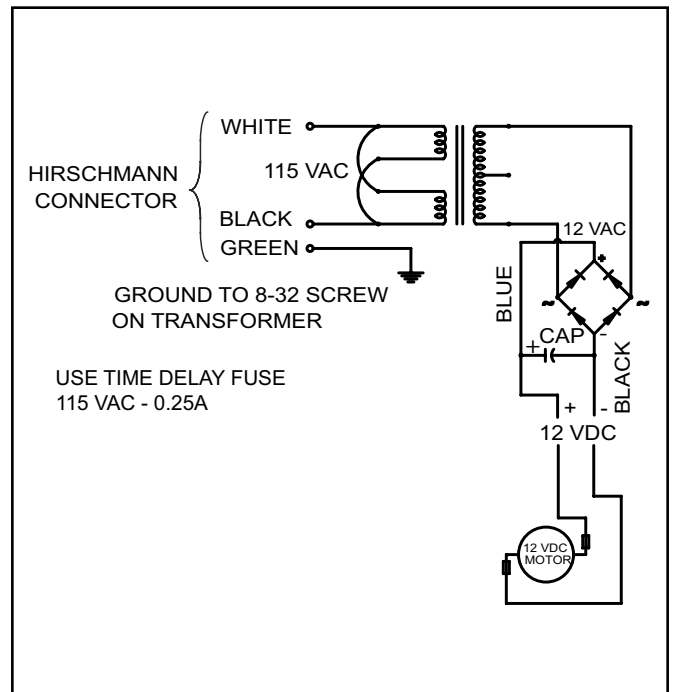

For 115 VAC without Timer

PUMP ORDERING INFORMATION

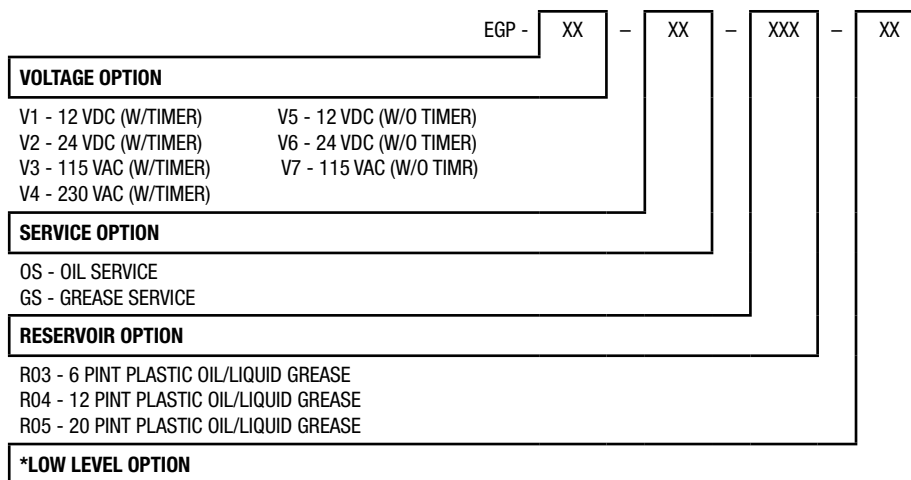

*FOR OIL SERVICE ONLY, OMIT IF NOT REQUIRED

REPLACEMENT PARTS ORDERING INFORMATION		
Description	Part No.	Old Part No.
Pump Assembly w/Timer (no reservoir), 12 VDC, Oil	Consult Factory	
Pump Assembly w/Timer (no reservoir), 12 VDC, Grease	-	550-001-685
Pump Assembly w/Timer (no reservoir), 24 VDC, Oil	Consult Factory	
Pump Assembly w/Timer (no reservoir), 24 VDC, Grease	563588	550-001-695S
Pump Assembly w/Timer (no reservoir), 115 VAC, Oil	Consult Factory	
Pump Assembly w/Timer (no reservoir), 115 VAC, Grease	Consult Factory	
Pump Assembly w/Timer (no reservoir), 230 VAC, Oil	Consult Factory	
Pump Assembly w/Timer (no reservoir), 230 VAC, Grease	Consult Factory	
Pump Assembly w/out Timer (no reservoir), 12 VDC, Oil	Consult Factory	
Pump Assembly w/out Timer (no reservoir), 12 VDC, Grease	Consult Factory	
Pump Assembly w/out Timer (no reservoir), 24 VDC, Oil	Consult Factory	
Pump Assembly w/out Timer (no reservoir), 24 VDC, Grease	Consult Factoru	
Pump Assembly w/out Timer (no reservoir), 115 VAC, Oil	564426	550-001-831
Pump Assembly w/out Timer (no reservoir), 115 VAC, Grease	Consult Factory	

ORDERING INFORMATION		
Description	Part No.	Old Part No.
Reservoir Assemblies, 6 pt, Plastic	-	550-050-960
Reservoir Assemblies, 12 pt, Plastic	-	550-050-970
Reservoir Assemblies, 20 pt, Plastic	-	550-050-980
Replacement Gear Pump	557822	540-800-603
Replacement Motor, 12 VDC, 115/230 VAC	557284	493-040-034
Replacement Motor, 24 VDC	557288	493-040-071
Replacement Transformer, 115 VAC	563135	492-210-009
Replacement Transformer, 230 VAC	-	492-210-008
Replacement Capacitor/Rectifier, 115/230 VAC	563136	492-240-098
Timer, 12 VDC, 115/230 VAC	557210	492-110-014
Tmer, 24 VDC	557211	492-110-015
20ft Cable w/Mating Connector, 12/24 VDC w/ Timer (4 Conductor)	563142	492-240-244
20ft Cable w/Mating Connector, 12/24 VDC w/o Timer, 115/230 VAC (all) (3 Conductor)	563140	492-240-196

INJECTORS AND MANIFOLDS

DESCRIPTION

Oil injectors in two types and grease injectors in one type (Figure 11) are available for use in the lubrication system. The first, a manifold injector, is designed specifically for mounting in the LubriSystem manifold. The second, a bearing point injector, is designed to be mounted at the lubrication point and does not require a manifold.

Manifold injectors are available for oil or grease and are positive-displacement, spring-loaded devices used in the LubriSystem manifold. These injectors are available in six displacements, from 0.0015 to 0.024 cu.in. (0.025 to 0.039 cm³) of lubricant per injector cycle. The choice of displacements fits a wide range of applications.

Input to the injector is from the manifold. Output is into lines delivering the lubricant to a specific lube point. Injectors are available in either an aluminum alloy or stainless steel. The inlet port of all injectors utilizes a 1/2-24 in tubing. An indicator adaptor is available to change 3/16 in tube connection to 1/8 in for use with 1/8 in tubing. Stainless steel injectors come standard with 1/8 in fittings.

Bearing point injectors are positive-displacement, spring-loaded devices that can be mounted directly at the lubrication point.



Figure 11. Injectors and Manifolds

Bearing point injectors are available in five output capacities, from 0.0015 to 0.012 cubic inches (0.025 to 0.2 cm³) of lubricant per injector cycle.

Input to the bearing point injector is from the pump, using a parallel branch from the main line. Bearing point injectors utilize a stainless steel body. The inlet port of this type of injector is 1/8-27 NPSF. The outlet port is a standard 1/8-27 NPTF male thread for attachment at the lubrication point.

Both injector styles are designed with a unique feature, allowing output capacity to be changed using adjustment spacers. This reduces the number of replacement injectors to be stocked. It also permits increasing/decreasing an injector's lube delivery capacity, in order to deal with unexpected needs to change the amount of lubricant delivered to lube points after installation.

Positive-displacement injectors dispense a precisely metered amount of oil or grease to a lube point with every lube cycle. Injectors are inexpensive and disposable. They should be replaced if not functioning properly. If an injector is to be disassembled for purposes of adding or deleting output adjustment spacers, great care must be taken to make sure both the inside and outside of the injectors are dirt-free when reassembled in the system.

An injector cycle indicator is available for use in system diagnostics. This cycle indicator can be attached to the output end of aluminum injectors. When the pump cycles, and the indicator is pressurized, the stem of the indicator extends. When the indicator is not pressurized the indicator stem is not visible. These indicators give an immediate visual indication that the injector has cycled. Injector cycle indicators are not available for stainless steel or bearing point injectors.

Manifolds are available in two types of materials: aluminum and stainless steel. The number and configuration of outlet ports can also be ordered to meet the specific needs of the system. Refer to pages 21, 22 and 23 for more specific information on dimensions and configurations of manifolds.

Aluminum manifolds are available with 4 outlet ports in an in-line, single-sided configuration. They are also available with 8 outlet ports in an in-line, double-sided configuration. These manifolds are dimensionally interchangeable with many of those used on other single-line parallel injector systems.

Stainless steel manifolds are available with 1, 2, 3, or 4 outlet ports in an in-line configuration. These also interchange with others in common use.

Plugs are available to close off any port not required. A torque of only 1 to 2 ft-lbs is required to provide a leak tight connection between the injectors and manifold.

INJECTOR OPERATION

Lubricant from the pump is supplied either to the manifold which, in turn, provides lubricant to the manifold injectors, or directly to the bearing point injector. Figure 12 represents a typical manifold injector. When pressurized lubricant enters the injector inlet, piston A shifts until the valve port is exposed. Lubricant flows through the valve port and is directed behind piston B to chamber B1. This forces piston B towards the outlet, dispensing a measured amount of lubricant from chamber B2 to the bearing.

When the pump has completed its dispense cycle it allows the pressure in the feed lines to vent. This allows piston A to shift back towards the inlet, opening the valve port to piston B. Piston B shifts, transferring the volume of lubricant in chamber B1 to chamber B2. This primes the injector in preparation for the next dispense cycle. This operation is identical in both types of injectors.

Note: Although oil and grease injectors operate in the same manner, each design has been optimized for use with its type of lubricant and system operating conditions. Oil injectors are designed for lower viscosity lubricants, higher cycle rates and lower operating pressure. They will not function properly with grease. Grease injectors are designed for grease consistency lubricants, low cycle rates and higher operating pressure. Their output accuracy will decrease with lighter lubricants and their life will be considerably reduced if used on high cycle rate systems.

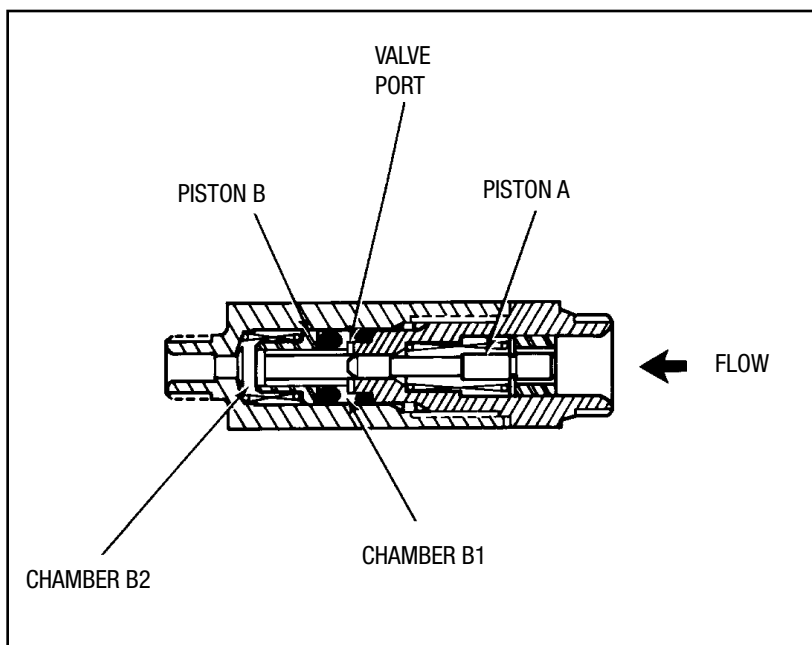

Figure 12. Injector Operation

INJECTOR CYCLE INDICATOR OPERATION

The injector cycle indicators are attached to the output side of aluminum injectors installed in an in-line manifold only. During the lube cycle, they provide a visual indication that the injector has cycled. Figure 13 represents an injector cycle indicator. As the pump pressurizes the injector, the injector piston moves toward the outlet, pushing a measured amount of lubricant toward the lubrication point. This piston contacts the plunger of the indicator moving it in the same direction. As the plunger moves toward the indicator outlet, the indicator stem is pushed toward the end of the indicator. This opens the outlet of the indicator releasing the lubricant and extends the indicator stem past the indicator body. This gives an indication that the injector has cycled.

When the pump has completed its cycle, and the injector piston has retracted, the spring-loaded indicator stem retracts, leaving the end of the stem flush with the indicator body and sealing the outlet port of the indicator.

The outlet of the injector cycle indicator accepts 1/8 inch tubing.

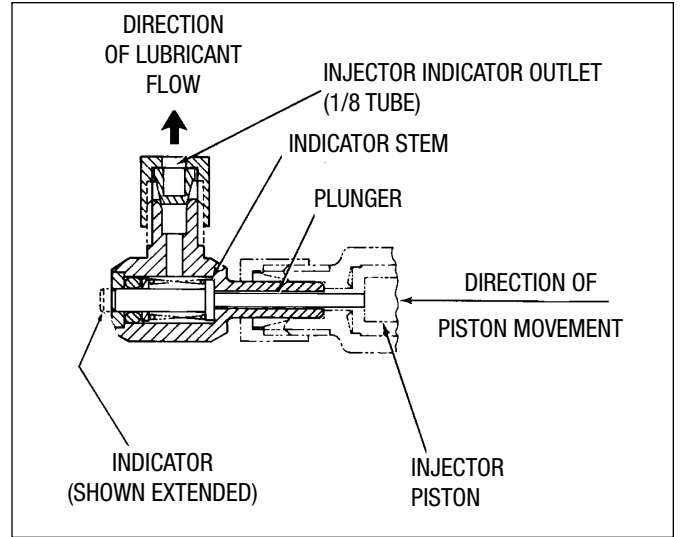

**Figure 13. Injector Cycle Indicator
Part No: 563769 (550-401-261)**

SPECIFICATION	
Manifold:	
Operating Pressure (max)	2500 psi (173 bar)
Injectors:	
Operating Pressure (max)	2500 psi (173 bar)
Min Pressure to Fire Injectors	450 psi (31 bar)
Vent Pressure	160 psi max (11 bar)
Min On-Time	30 sec
Min Off-Time	3 min
Torque Specs:	
Installing Injector into Manifold	2-3 ft lbs
Tightening Tube Nut	18-36 in lbs

DIMENSIONS

Injectors

All manifold injectors are approximately 2.125 inches (54 mm) long with a 0.625 inch (15.88 mm) hex body. For injectors utilizing from one to four output adjustment spacers add 0.04 inch (1 mm) per spacer to the length.

All bearing point injectors are approximately 2.5 inches (63.5 mm) long with a 0.625 (15.88 mm) hex body. For injectors utilizing from one to four output adjustment spacers add 0.04 inch (1 mm) per spacer to the length. Figure 14 provides dimensions for the two types of injectors.

Manifolds

Figures 15 and 16 provide dimensions for aluminum and stainless steel manifolds.

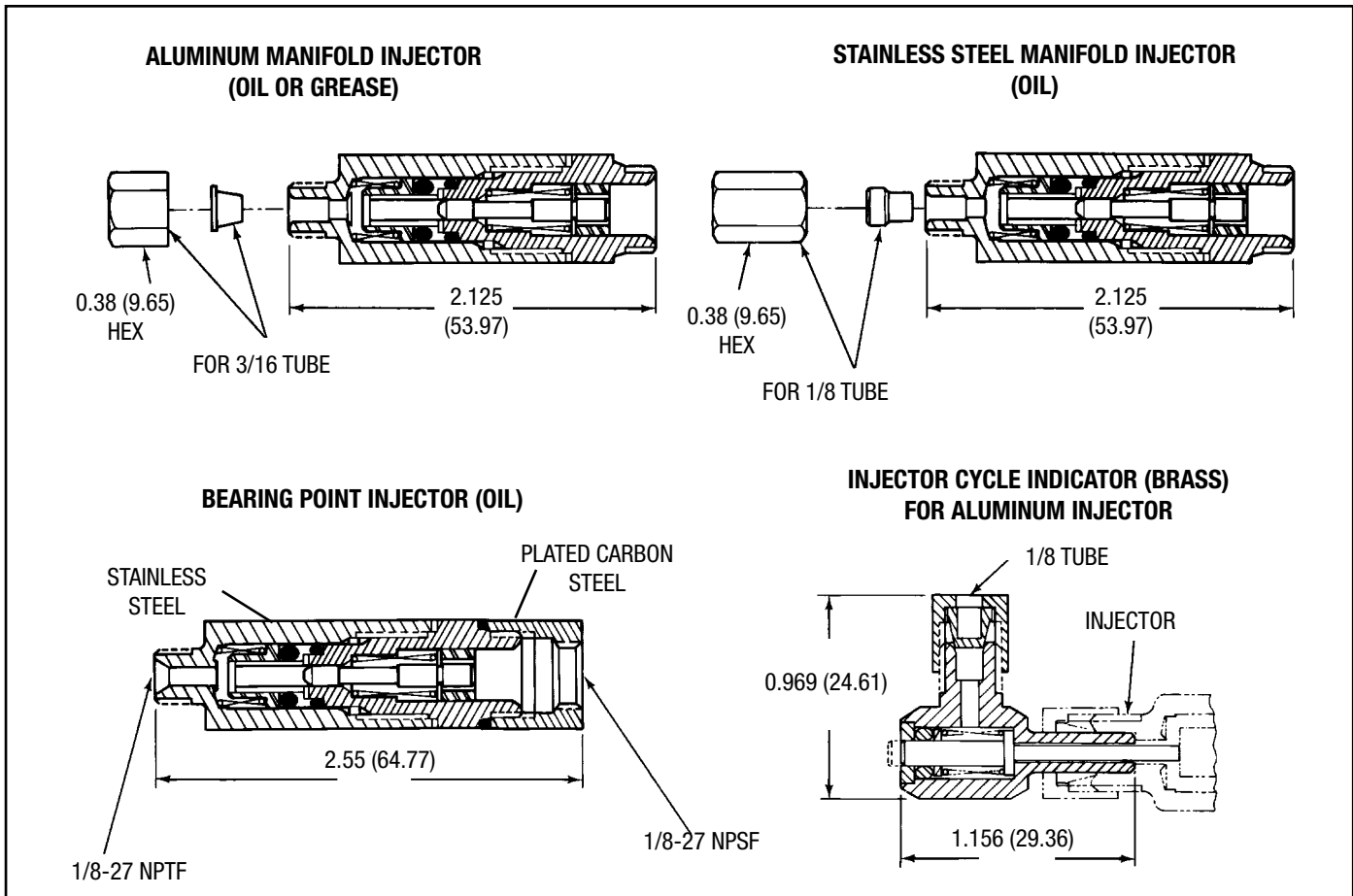
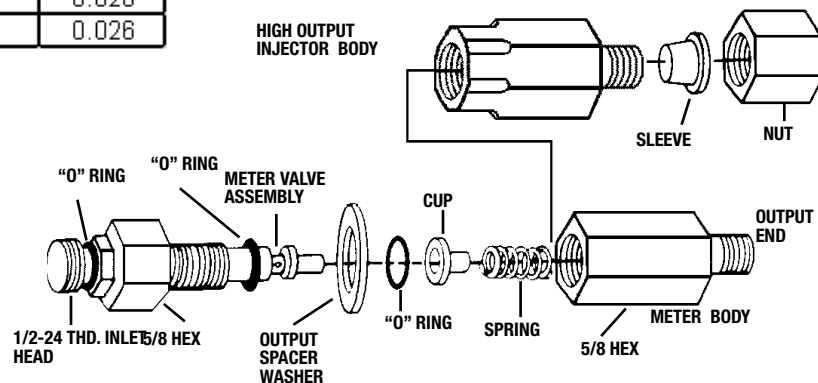

Figure 14. Injector and Indicator Dimensions

Injectors can be identified by the following characteristics:

Meter Size	No. of Washers in Meter Body	Turned Hex	Output (Cu.in.)
0	0	no	0.002
1	1	no	0.005
2	2	no	0.009
3	3	no	0.012
4	4	no	0.020
8	4	yes	0.026



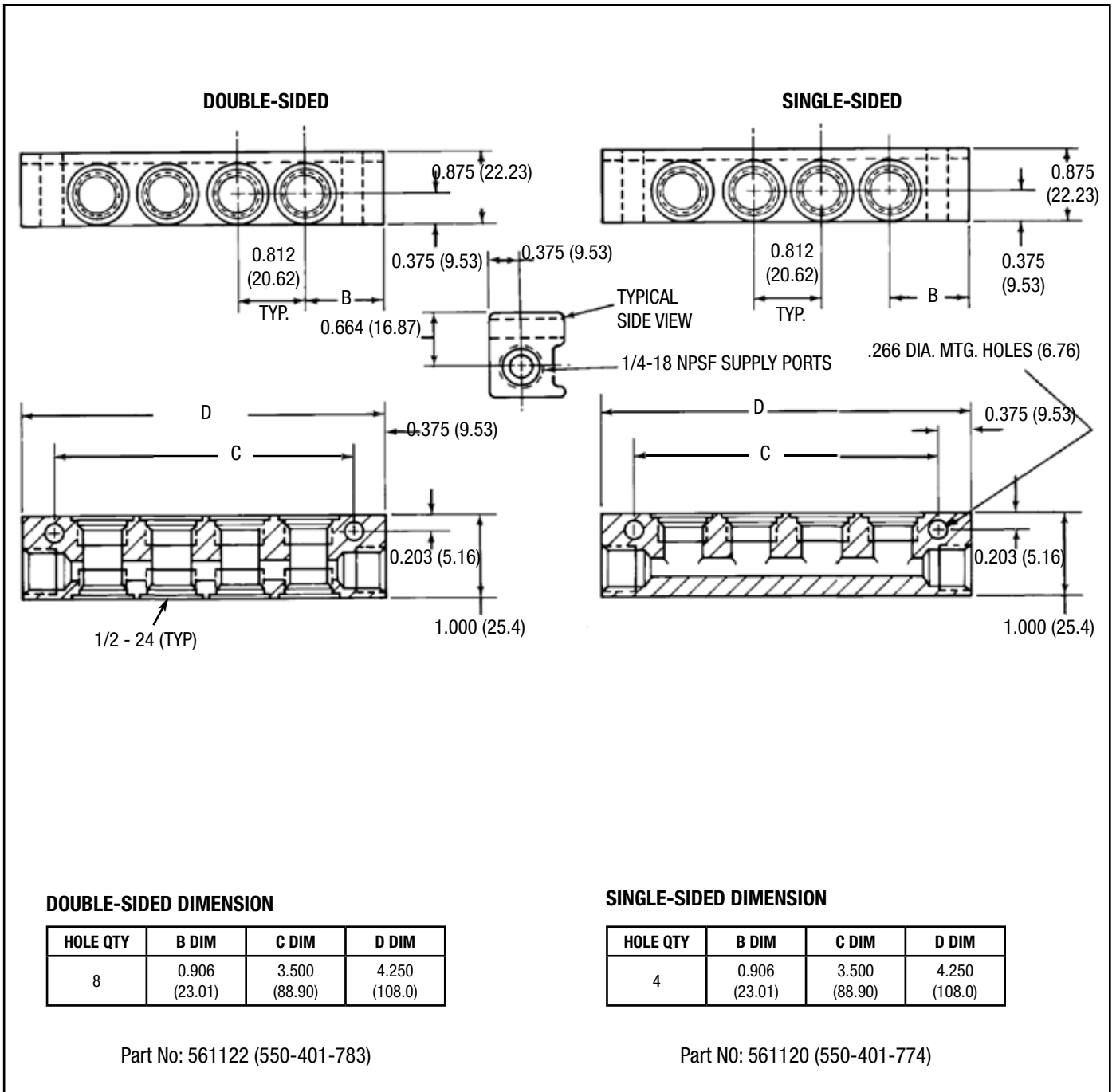
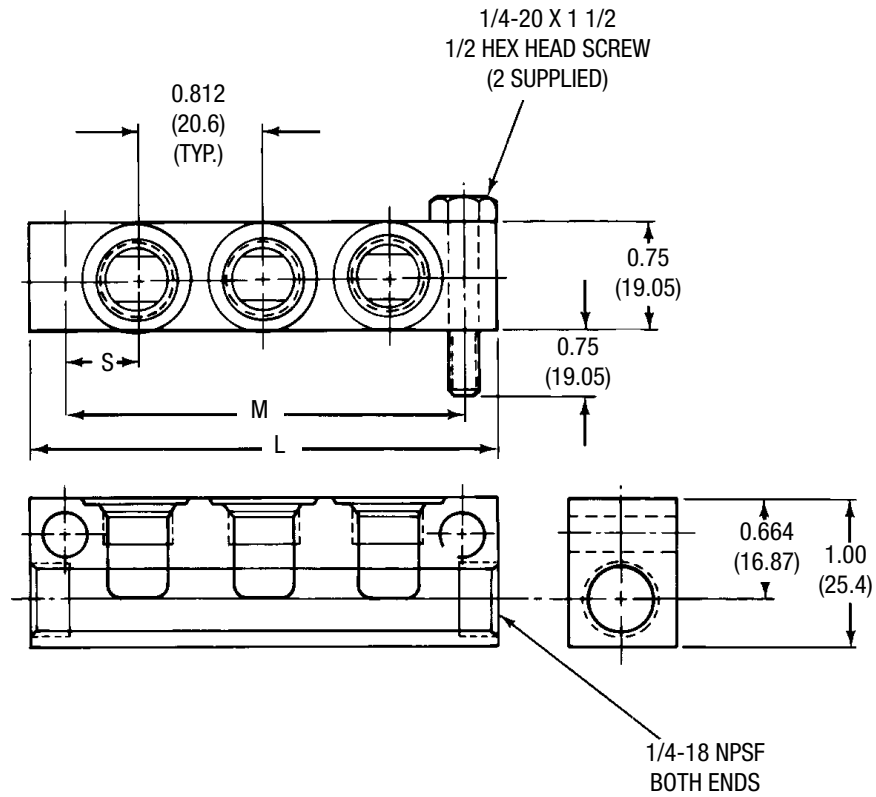

Figure 15. Extruded Aluminum Manifold Dimensions and Configurations



STAINLESS STEEL

NO. OF PORTS	S	M	L	PART NO.	OLD PART NO.
1	0.625 (15.8)	1.25 (31.7)	1.75 (44.5)	563764	550-401-101
2	0.594 (15.1)	2.0 (50.8)	2.5 (63.5)	563765	550-401-102
3	0.563 (14.3)	2.75 (69.8)	3.25 (82.6)	563766	550-401-103
4	0.532 (13.5)	3.5 (88.9)	4.0 (101.6)	563767	550-401-104

Figure 16. Stainless Steel Manifold Dimensions and Configurations

ORDERING INFORMATION

LUBRISYSTEM MANIFOLD AND ACCESSORIES		
Description	Part No.	Old Part No.
Manifolds - Stainless Steel		
1 Port Manifold	563764	550-401-101
2 Port Manifold	563765	550-401-102
3 Port Manifold	563766	550-401-103
4 Port Manifold	563767	550-401-104
Manifolds - Aluminum		
4 Port Manifold	561120	550-401-774
8 Port Manifold Double Sided	561122	550-401-783
Manifold Accessories		
Manifold Injector Port Plugs		
Aluminum Manifold	15M038	550-350-040
Stainless Steel Manifold	561115	550-401-120
End of Line Manifold Plugs		
Aluminum Manifold	555808	550-050-210
Stainless Steel Manifold	556425	412-700-394

INJECTOR ACCESSORIES		
Description	Part No.	Old Part No.
Inlet Adaptor, 1/2-27 in FM x 1/8 in NPSF Female	Dis	550-401-820
Outlet Adaptor, 3/8-24 in FM x 1/8 NPT Female	-	550-402-020
Injector Outlet Plug	557901	550-150-130
Aluminum Ouput Adjustment Spacer	557898	550-150-020
Stainless Steel Ouput Adjustment Spacer	557905	550-150-180
Injector Cycle Indicator	563769	550-401-261

Size #	Output cu.in. (cm ³)	Adjustment Spacers	Aluminum Alloy Injectors (Oil)		Aluminum Alloy Injectors (Grease)		Stainless Steel Injectors (Oil)		Bearing Point Injectors (Oil)	
			Part No.	Old Part No.	Part No.	Old Part No.	Part No.	Old Part No.	Part No.	Old Part No.
0	.002 (0.033)	-	563628	550-100-001	563627	550-100-000	-	550-100-110	-	550-100-480
1	.005 (0.082)	1	563630	550-100-011	563629	550-100-010	-	550-100-120	-	550-100-490
2	.009 (0.148)	2	563632	550-100-021	563631	550-100-020	-	550-100-130	-	550-100-500
3	.012 (0.197)	3	563634	550-100-031	563633	550-100-030	-	550-100-140	-	550-100-510
4	.020 (0.328)	4	563636	550-100-041	563635	550-100-040	563639	550-100-150	-	550-100-520
8	.026 (0.426)	4	563638	550-100-081	563637	550-100-080	-	-	-	-
Spart O-Ring			556587	423-700-052	556586	423-700-051	556587	423-700-052	-	-

ACCESSORIES/HARDWARE

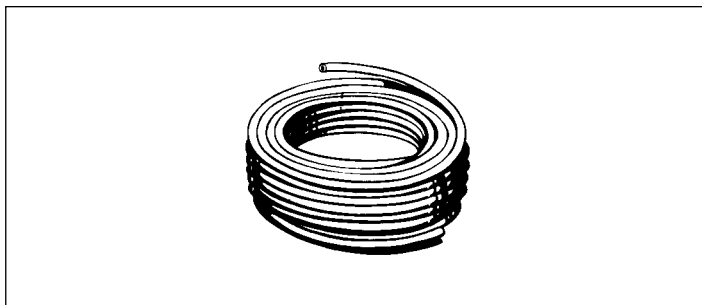

Figure 17. Tubing (unplasticized nylon)

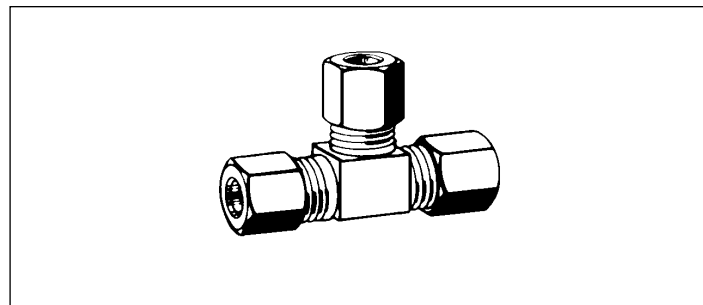

Figure 18. Union

HEAVYWALL LUBE LINES (TUBING)		
Description	Part No.	Old Part No.
Main Line (pump to manifold): 5/16 in OD x .059 wall (7.9 x 1.5), black, 60 ft (18.3 m) Burst Pressure Min - 1500 psi (103 bar) at 75°F (24°C)	561132	550-450-230
Point Distribution Line (injector to lube point): 3/16 in OD x .044 wall (4.8 x 1.1), black, 60 ft (18.3 m) Burst Pressure Min - 2000 psi (138 bar) at 75°F (24°C)	561131	550-450-190

TEES AND UNIONS		
Description	Part No.	Old Part No.
Male Branch Tee, 5/16 tube, 1/8 NPTF Brass	556636	435-410-040
Union Tee, 5/16 tube, Brass	556637	435-420-030
Union, 3/16 tube, Brass	556647	435-470-020
Union, 5/16 tube, Brass	556648	435-470-040

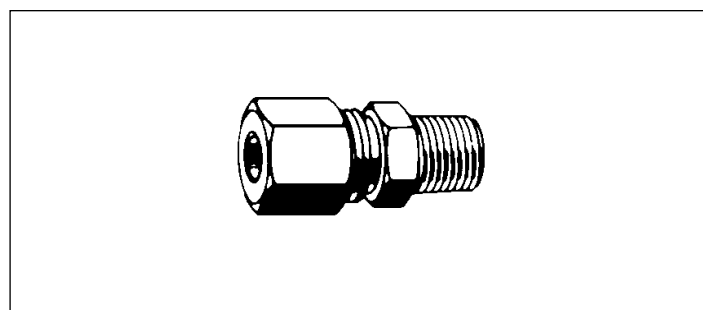

Figure 19. Connectors

SELF-ALIGNING FERRULES AND NUTS		
Description	Part No.	Old Part No.
Brass Nut, w/captive ferrule, 3/16 tube	556660	435-702-340
Brass Nut, w/captive ferrule, 5/16 tube	556666	435-702-503
Stainless Steel Nut, 1/8 tube	556651	435-500-150
Stainless Steel Ferrule, 1/8 tube	556654	435-510-050
Brass Inserts for 5/16 tubing (pack of 20)	557963	550-402-330

BRASS CONNECTORS		
Description	Part No.	Old Part No.
Female Connector, 3/16 tube x 1/8 NPTF	556642	435-450-020
Female Connector, 5/16 tube x 1/8 NPTF	556643	435-450-050
Male Connector, 3/16 tube x 1/8 NPTF	556644	435-460-030
Male Connector, 5/16 tube x 1/8 NPTF	556645	435-460-060
Male Connector, 5/16 tube x 1/4 NPTF	556646	435-460-070

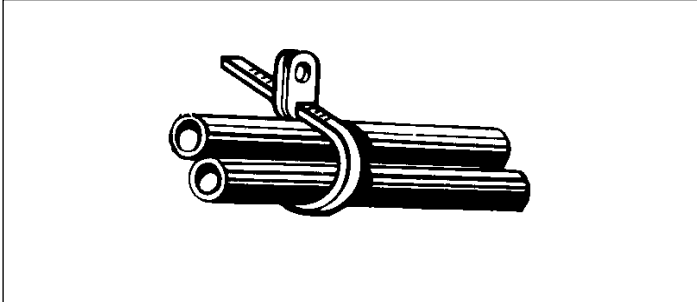

Figure 20. Tubing Straps

TUBING STRAPS		
Description	Part No.	Old Part No.
100 pieces, 11.5 in (292 mm)	563770	550-402-340

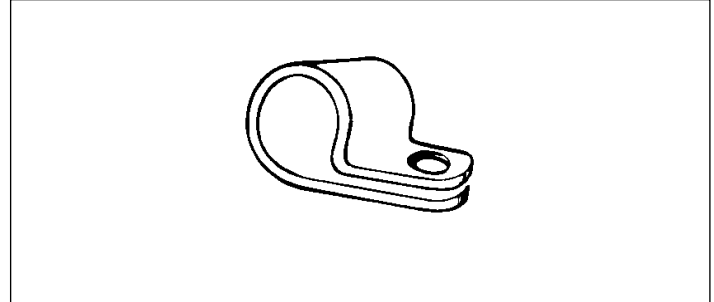

Figure 22. Harness Clamps

HARNESS CLAMPS AND BRACKETS		
Description	Part No.	Old Part No.
5/16 (7.94) diameter	557943	550-400-040
3/8 (9.53) diameter	557946	550-400-070
7/16 (11.11) diameter	557944	550-400-050
1/2 (12.7) diameter	557947	550-400-080
5/8 (15.22) diameter	557945	550-400-060

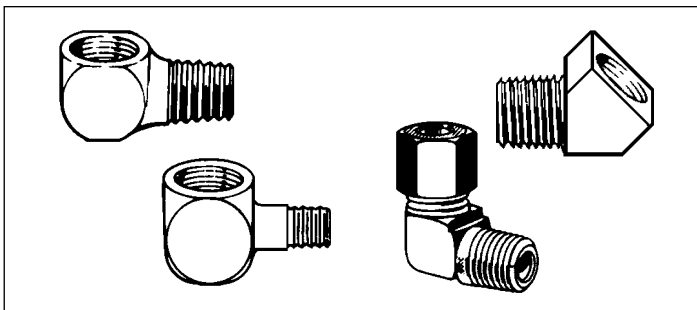

Figure 21. Elbows

ELBOWS		
Description	Part No.	Old Part No.
Steel Pipe and Adaptor Elbows		
1/4-28 (male) x 1/8 NPTF (female), 90° Adapter Elbow	15K740	550-400-800
90° Street Elbow, 1/8 NPTF	15K783	509-110-000
45° Street Elbow, 1/8 NPTF	557395	509-111-000
Brass Male Tube Elbows		
3/16 tube x 1/8 NPTF	556638	435-440-030
5/16 tube x 1/8 NPTF	556639	435-440-060
5/16 tube x 1/4 NPTF	556640	435-440-070

MISCELLANEOUS		
Description	Part No.	Old Part No.
Air Line Restrictor, 1/2 x 1/8, M to F Pipe	561113	550-400-010
Air Line Restrictor, 3/8 x 1/8, M to F Pipe	561114	550-400-460
Pressure Gauge Kit, 3000 psi for Air Pump	–	560-001-780
Fill Studs, Pneumatic Oil Pumps	563155	506-189-010
Pneumatic & Hand Grease Pumps	557374	506-189-001
Electric Oil & Fluid Grease Pumps	557880	550-050-300
Fill Couplers, mate w/above fill studs		
Pneumatic Oil Pump	558906	506-322-000
Pneumatic & Hand Grease Pumps	558906	506-322-000
Electric Oil & Fluid Grease Pumps	557877	550-050-230

HOW-TO-ORDER LUBRISYSTEM

ANALYZING SYSTEM REQUIREMENTS

1. Determine individual bearing requirements. Graco literature No. L20115 provides a procedure for calculating the lubricant volume requirement for individual lube points.
2. Analyze bearing locations and group those that can conveniently be fed from a single manifold. See ordering instructions.
3. Analyze routine maintenance setup to determine reservoir options and other accessories required.

ORDERING INSTRUCTIONS

4. Select the quantity of each injector size required.
5. Specify the manifolds required based on the groupings of injectors.
6. *Order a Timer or Controller.
7. Select pump/reservoir configuration and specify part number using one of the following:
 - Grease Reservoir - specify appropriate assembly number.
 - Oil Reservoir - specify appropriate assembly number.
8. *Order Part No. 553315 (521-001-020), 115 VAC or 553332 (521-002-100), 24 VDC solenoid valve. (Install in pump air inlet port.)
9. Specify appropriate pressure switch, in one is required, using Bulletin No. L15521. Part No. 557828 (542-210-107) is usually used.
10. Specify Part No. 557559 (514-215-001) if a pressure gauge is required (0-3000 psir). See Bulletin No. L15326.
11. Select fittings, accessories and mounting hardware to complete installation.

*Required only for air operated pumps.

FOR MORE INFORMATION

Literature No. L20102 - LubriSystem Design Guide. Guidelines and information for LubriSystem component selection and design calculation charts.

Literature No. L14521 - Solid-State Timer

Literature No. L14530 - TC-1000 Timer/Counter

Literature No. L14540 - LC-1000 Controller †

Literature No. L14750 - WMP III Maxi-Monitor †

Literature No. L14760 - Multi Purpose Controller †

Literature No. L15521 - Pressure Switch

Literature No. L20115 - Procedure for calculating the lubricant volume requirement for various types of rotating and moving lubrication points.

† Requires a system mounted pressure switch.

All written and visual data contained in this document are based on the latest product information available at the time of publication. Graco reserves the right to make changes at any time without notice.

Contact us today!

To receive product information or talk with a Graco representative, call 800-533-9655 or visit us online at www.graco.com.



©2006-2009 Graco Inc. Form No. L12100 Rev. B 1/09 Printed in U.S.A. All other brand names or marks are used for identification purposes and are trademarks of their respective owners. All written and visual data contained in this document are based on the latest product information available at the time of publication. Graco reserves the right to make changes at any time without notice.